

REVISIONS					
REV	ECO	DESCRIPTIONS	DWN	CKD	APVD
1	///	ORIGINATED	JNR		
			10/31/2001		

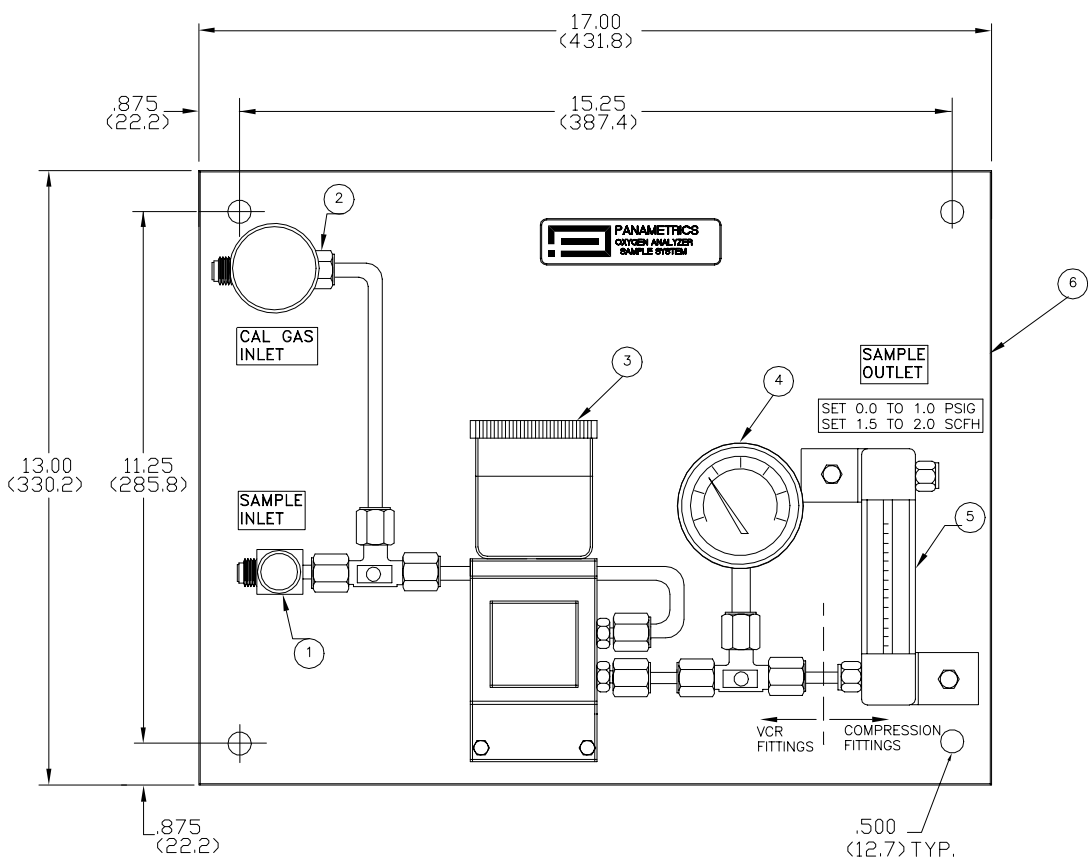

- NOTES:
1. SS91A-0-0-0-0
  2. SAMPLE INLET & CAL GAS INLET:  
1/4" INTERGAL MALE VCR  
SAMPLE OUTLET: 1/4" TUBE FITTING
  3. INCHES  
(MM)
  4. REF. DWG. 732-985BM

UNLESS OTHERWISE SPECIFIED DIMENSIONS ARE IN INCHES TOLERANCES ARE		<b>PANAMETRICS</b> WALTHAM, MASS. 02154-3497	
FRACTIONS	DECIMALS	ANGLES	TITLE
± //	.XX ± .01 ± //	± //	SAMPLE SYSTEM ASSEMBLY
	.XXX ± .005		
	SURFACE FINISH 125 ✓		
DRAWN	JNR 12/12/97	ENGINEER	
CHECKED			
	RIN		
1	///	MODEL NO.	985
REV	ECO	SCALE	DO NOT SCALE DWG
			SHEET 1 OF 1

SIZE	DRAWING NUMBER	REV
C	732-985AS	1

